

WIRING TABLE

P1		P2	
A1	NC	B1	NC
A2	GND	B2	GND
A3	RX1+	B3	TX1+
A4	RX1-	B4	TX1-
A5	GND	B5	GND
A6	RX2+	B6	TX2+
A7	RX2-	B7	TX2-
A8	GND	B8	GND
A9	SIDEBAND	B9	SIDEBAND
A10	SIDEBAND	B10	SIDEBAND
A11	GND	B11	GND
A12	SIDEBAND	B12	SIDEBAND
A13	SIDEBAND	B13	SIDEBAND
A14	GND	B14	GND
A15	RX3+	B15	TX3+
A16	RX3-	B16	TX3-
A17	GND	B17	GND
A18	RX4+	B18	TX4+
A19	RX4-	B19	TX4-
A20	GND	B20	GND
A21	NC	B21	NC
B1	NC	A1	NC
B2	GND	A2	GND
B3	TX1+	A3	RX1+
B4	TX1-	A4	RX1-
B5	GND	A5	GND
B6	TX2+	A6	RX2+
B7	TX2-	A7	RX2-
B8	GND	A8	GND
B9	SIDEBAND	A9	SIDEBAND
B10	SIDEBAND	A10	SIDEBAND
B11	GND	A11	GND
B12	SIDEBAND	A12	SIDEBAND
B13	SIDEBAND	A13	SIDEBAND
B14	GND	A14	GND
B15	TX3+	A15	RX3+
B16	TX3-	A16	RX3-
B17	GND	A17	GND
B18	TX4+	A18	RX4+
B19	TX4-	A19	RX4-
B20	GND	A20	GND
B21	NC	A21	NC

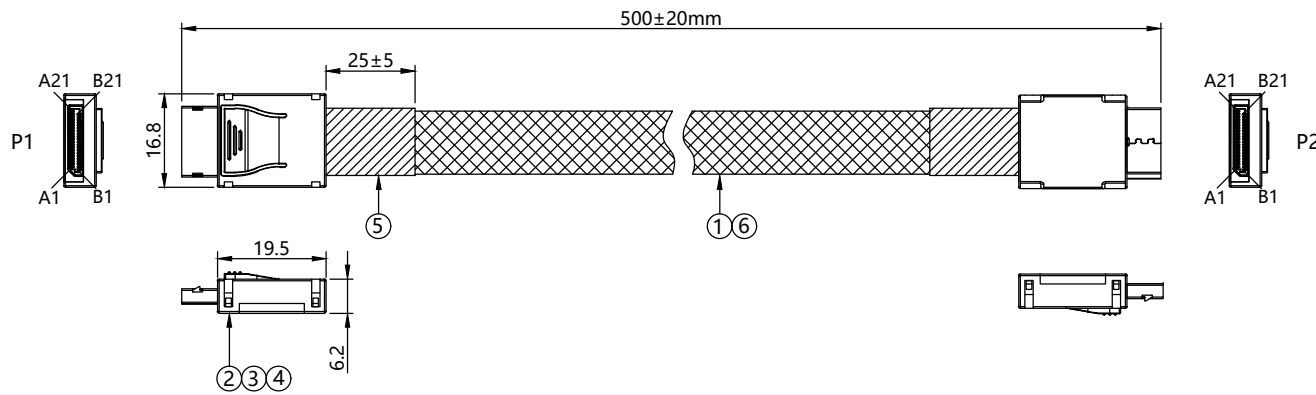

电气特性:

- 100%开路、短路、断路测试。
- 绝缘阻抗: 10M Ohm Min
- 导通阻抗: 2 Ohm MAX
- 耐压: DC 300V,0.01/Sec

NO.	PART NAME	SPEC DESCRIPTION	QT'Y	UNIT
6	网管	网管 OD10MM,PET,黑色	A/R	mm
5	醋酸胶布	醋酸胶布, W=25±5MM,黑色	A/R	mm
4	外壳	OCULINK 4I 顶盖 PC+ABS+30%GF, 黑色	2	PCS
3	外壳	OCULINK 4I 下盖 PC+ABS+30%GF, 黑色	2	PCS
2	PCBA	OCULINK 4I 连接器&OCULINK 4I PCB 88±8 ohm	2	PCS
1	线材	SAS4.0,UL20744(32AWG*2C+2D)+AM,蓝色,85±5 ohm	A/R	mm

A	INITIAL RELEASE		25/09/10	
REV	DESCRIPTION OF CHANGE		DATE	
TOLERANCE				
INCHES			MM	
.X	.015	.30	OIKWAN® 东莞市蔼群实业有限公司 DONGGUAN AIQUN INDUSTRIAL CO.,LTD	
.XX	.010	.10		
.XXX	.005	.05		
DRAWN BY	Wu SiYuan		SCALE	NONE
			UNIT	MM
			SHEET	1/1
			DATE	25/09/10
CHECK BY			CUSTOMER:	REV A
			DWG NO:	
			TITLE: OCULINK 8611 to 8611	
CUSTOMER P/N:			P/N:1.AMS880010009	